

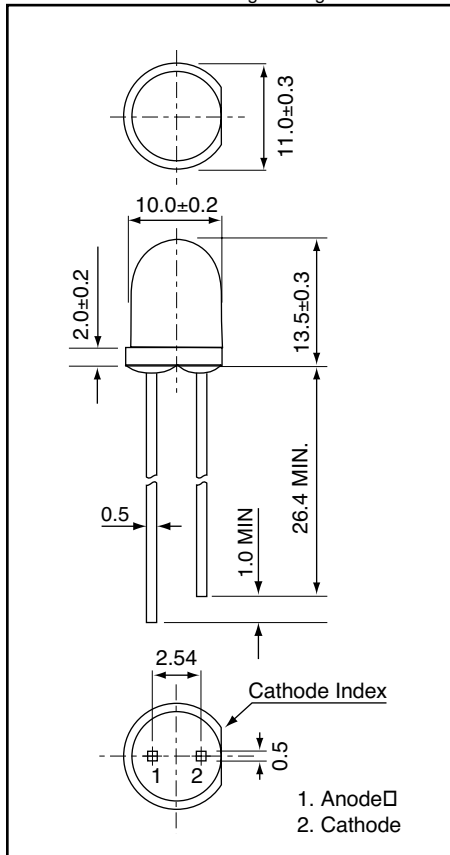

Weight: 1.0 g Unit: mm



AND190HAP

InGaAlP High Brightness Amber Light Emission T-3 Package (10 mm)

Features

- New emission material (InGaAlP) amber LED
- Peak wavelength ($\lambda_p = 612$ nm) high bright emission
- All plastic mold type, clear colorless lens
- Low drive current, (forward current = 1 to 20 mA)
- Excellent On-Off contrast ratio
- Fast response time, capable of pulse operation
- High power luminous intensity
- Suitable for Outdoor Message Signboards

• RoHS Compliant

Maximum Ratings ($T_a = 25^\circ\text{C}$)

| Characteristics | Symbol | Rating | Unit |
|-----------------------------|-----------|------------|------------------|
| Forward Current | I_F | 50 | mA |
| Reverse Voltage | V_R | 5 | V |
| Power Dissipation | P_D | 125 | mW |
| Operating Temperature Range | T_{Opr} | -40 to 100 | $^\circ\text{C}$ |
| Storage Temperature Range | T_{Stg} | -40 to 100 | $^\circ\text{C}$ |

Electro-Optical Characteristics ($T_a = 25^\circ\text{C}$)

| Characteristics | Symbol | Test Condition | Minimum | Typical | Maximum | Unit |
|--------------------------|-----------------|------------------|---------|---------|---------|---------------|
| Forward Voltage | V_F | $I_F = 20$ mA | – | 2.1 | 2.8 | V |
| Reverse Current | I_R | $V_R = 4$ V | – | – | 50 | μA |
| Luminous Intensity | I_V | $I_F = 20$ mA | 4,500 | 8,000 | – | mcd |
| Peak Emission Wavelength | λ_p | $I_F = 20$ mA | – | 612 | – | nm |
| Spectral Line Half Width | $\Delta\lambda$ | $I_F = 20$ mA | – | 15 | – | nm |
| Dominant Wavelength | λ_d | $I_F = 20$ mA | – | 605 | – | nm |
| Full Viewing Angle | θ | $I_V = 1/2$ Peak | – | 6 | – | degree |

Precaution

Please be careful of the following:

1. Soldering temperature: 260 $^\circ\text{C}$ max
Soldering time: 5 sec. max
Soldering portion of lead: up to 1.6 mm from the body of the device
2. The lead can be formed up to 5 mm from the body of the device without forming stress.
Soldering should be performed after the lead forming.

Product specifications contained herein may be changed without prior notice.

It is therefore advisable to contact Purdy Electronics before proceeding with the design of equipment incorporating this product.

