



ANDpSi104EA5S-4HB

10.4" XGA Color p-Si TFT LCD Module

The ANDpSi104EA5S-4HB is 1024 x 768 Color TFT display that utilizes new poly-silicon (p-Si) technology to provide a brighter, thinner and lighter display with high-resolution. The p-Si TFT technology allows the row and column LCD drivers to be fabricated directly on the LCD glass. This eliminates the need for discrete TAB drivers. This reduces the thickness, weight and overall size of the display. The LVDS interface allows fast data transfer. The triple CCFL backlight offers an ultra-high bright display. This makes the display ideal for outdoor, sunlight readable applications.

Features

• RoHS Compliant

- p-Si construction with drivers on glass
- High luminance
- Triple CCFL backlight
- 6-bit (256K) or 8-bit (16.7M)
- 10.4" XGA (1024 x 768 pixels color display)
- LVDS Interface system
- High-bright, Display Terminals, Scientific, Medical, Test & Measurement Instruments, and Office Automation Equipment

Mechanical Characteristics

| Item | Specification | Unit |
|--------------------|--------------------------------------|--------|
| Outline Dimensions | 237.7 (W) x 173.2 (H) x 14.6 max (D) | mm |
| Number of Pixels | 1024 (W) x 768 (H) | pixels |
| Active Area | 210.432 (W) x 157.824 (H) | mm |
| Pixel Pitch | 0.2055 (W) x 0.2055 (H) | mm |
| Weight (approx.) | 465 | gram |
| Backlight | 3 CCFL, high-bright | - |

Electrical Characteristics (Ta = 25°C)

| Item | Symbol | Min. | Typ. | Max. | Unit |
|--|----------------------|------------------------|-------|------------------------|---------|
| Supply Voltage I _{FL} =5 mA(rms) | V _{DD} | 3.0 | 3.3 | 3.6 | V |
| | V _{FL} | - | (600) | - | V(rms) |
| FL Start Voltage (Ta = 0°C) | - | 1200 | - | - | V(rms) |
| Differential Input High Threshold | V _{IH} | (V _{IS})+0.1 | - | - | V |
| Differential Input Center Threshold | V _{IS} | 0.5 | 1.2 | 1.5 | V |
| Differential Input Low Threshold | V _{IL} | - | - | (V _{IS})-0.1 | V |
| Current Consumption | I _{DD} (*2) | - | 250 | - | mA(rms) |
| | I _{FL} (*3) | 2.0 | 7.0 | 7.5 | |
| Power Consumption (*2, *3) @ 890cd/m ² | - | - | (15) | - | W |

*1: Refer to "Timing Chart" and LVDS (THC63LVDF84A-85) specifications by Thine Electronics, Inc. corporation.

*2: 8 color bars pattern

*3: Excepting the efficiency FL inverter

Absolute Maximum Ratings

| Item | Symbol | Min. | Max. | Unit |
|-----------------------|------------------|------|-----------------------|-------|
| Supply Voltage | V _{DD} | -0.3 | 4.0 | V |
| | V _{FL} | 0 | 2.0 | kVrms |
| FL Driving Frequency | f _{FL} | - | 100 | kHz |
| Input Signal Voltage | V _{IN} | -0.3 | V _{DD} + 0.3 | V |
| Operating Temperature | T _{op} | 0 | 50 | °C |
| Storage Temperature | T _{stg} | -20 | 60 | °C |
| Humidity | - | 10 | 90 | % RH |

Optical Characteristics (Ta = 25°C)

| Item | Symbol | Min. | Typ. | Max. | Unit |
|---|------------------|------|-------|------|-------------------|
| Contrast | CR | 100 | 250 | - | - |
| Response | t _{on} | - | - | 50 | ms |
| | t _{off} | - | - | 50 | ms |
| Luminance I _{FL} =7 mA(rms) | L | 140 | 1000 | - | cd/m ² |
| Viewing Angle | L/R | - | 60/60 | - | ° |
| | U/D | - | 45/45 | - | ° |

Product specifications contained herein may be changed without prior notice.

It is therefore advisable to contact Purdy Electronics before proceeding with the design of equipment incorporating this product.

Timing Specifications

| Item | Symbol | Min | Typ | Max | Unit |
|--------------------------|--------|--------------------|-----------|----------------|---------|
| Frame Period | t1 | 778 x t4 - | - - | 860 x t4 - | - ms |
| Vertical Display Term | t2 | 768 x t4 | 768 x t4 | 768 x t4 | - |
| Vertical Blanking Term | t3 | 10 x t4 | - | 92 x t4 | - |
| 1 Line Scanning Time | t4 | 1319 x t7 20.04 | - - | 1600 x t7 - | us |
| Horizontal Display Term | t5 | 1024 x t7 | 1024 x t7 | 1024 x t7 | - |
| Horizontal Blanking Term | t6 | 295 x t7 | - | 500 x t7 | - |
| Clock Period | t7 | 15 | 15.38 | - | ns |
| V-Sync Pulse Width | tvw | 3 x t4 | - | 7 x t4 | - |
| V-Sync Set up Time | tvsu | 8 x t7 | - | - | - |
| V-Sync Hold Time | tvhd | thbp+16 x t7 | - | - | - |
| Vertical Front Porch | tvfp | 2 x t4 | - | - | - |
| Vertical Back Porch | tvbp | 6 x t4 | - | - | - |
| Horizontal Period | th | 1319 x t7 20.04 | - | 1600 x t7 - | - us |
| H-Sync Pulse Width | thw | 8 x t7 | - | - | - |
| Horizontal Front Porch | thfp | 4 x t7 | - | 500 x t7 | - |
| Horizontal Back Porch | thbp | 8 x t7 | - | 492 x t7 | - |
| thw+thbp | | 16 x t7 | - | 500 x t7 | - |
| DE Pulse Width | twde | 1024 x t7 | 1024 x t7 | 1024 x t7 | - |

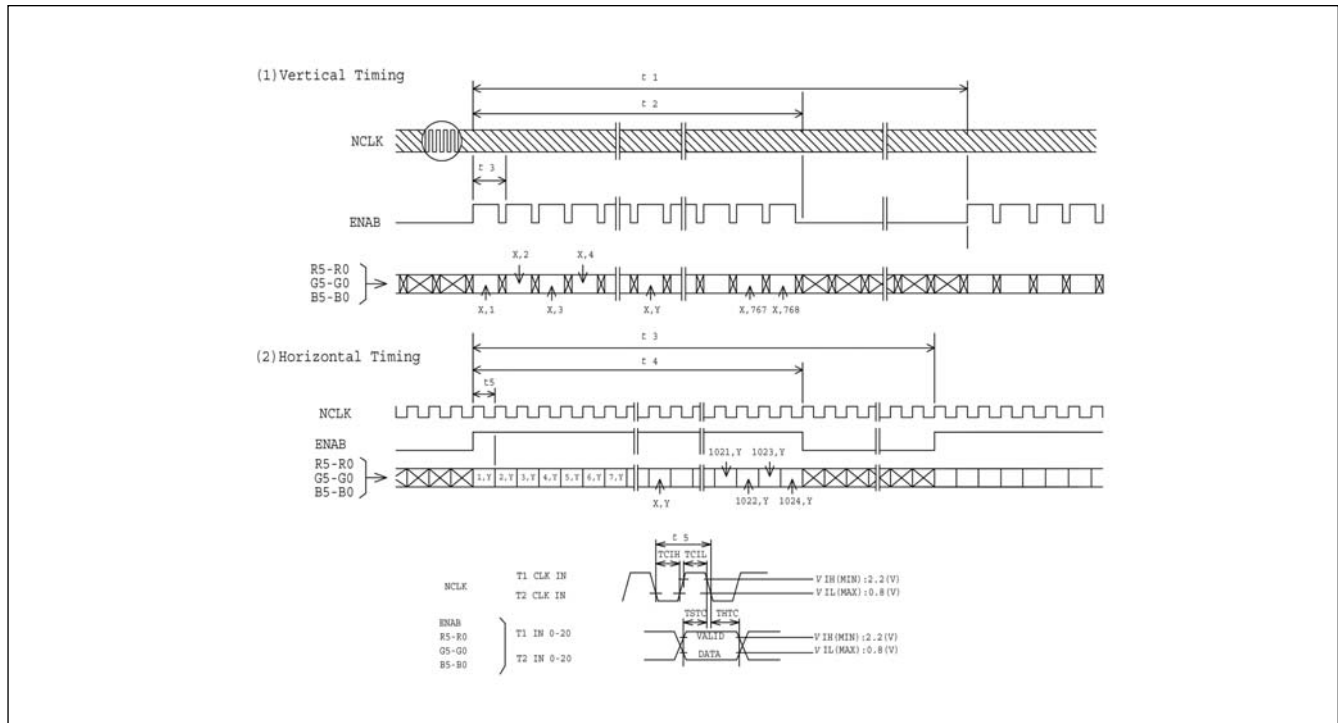
Timing Chart

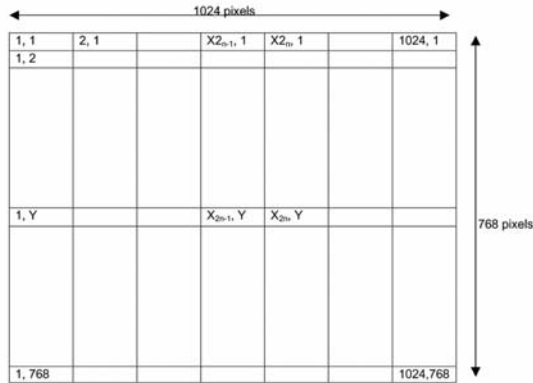

Recommended Inverter:

Block Diagram

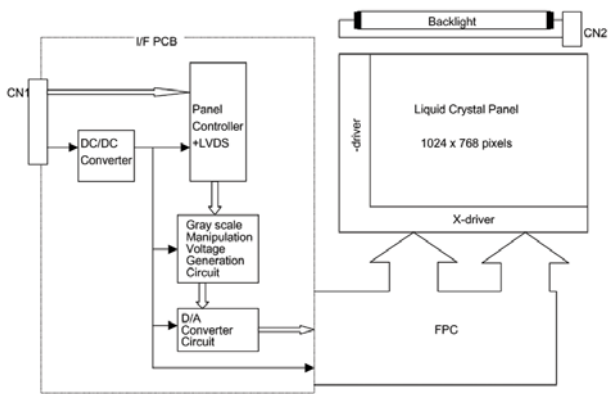

1) Drivers are fabricated on the LCD glass

2) Connectors

DF19L-14P-1H/Hirose Electric Co., Ltd.
Mating Connector - DF19G-14S-11C/Hirose

HV-2S-C1/Japan Aviation Electronics Industry., Ltd.
Mating Connector - HV-2P-HF/JAEI

Connector Pin Assignment for Interface

CN1 Input Signal (1)

| Terminal No. | Symbol | Function |
|--------------|-----------------|---------------------------------------|
| 1 | V _{DD} | +3.3V Power Supply |
| 2 | V _{DD} | +3.3V Power Supply |
| 3 | GND | Ground |
| 4 | GND | Ground |
| 5 | IN0- | Trans Data of Pixels 0 (Negative : -) |
| 6 | IN0+ | Trans Data of Pixels 0 (Positive : +) |
| 7 | IN1- | Trans Data of Pixels 1 (Negative : -) |
| 8 | IN1+ | Trans Data of Pixels 1 (Positive : +) |
| 9 | IN2- | Trans Data of Pixels 2 (Negative : -) |
| 10 | IN2+ | Trans Data of Pixels 2 (Positive : +) |
| 11 | CLK- | Sampling Clock (Negative : -) |
| 12 | CLK+ | Sampling Clock (Positive : +) |
| 13 | GND | Ground |
| 14 | GND | Ground |

CN2 CCFL Power Source

| Terminal No. | Symbol | Function |
|--------------|------------------|----------------------------------|
| 1 | V _{FLL} | CCFL Power Supply (Low Voltage) |
| 2 | V _{FLH} | CCFL Power Supply (High Voltage) |

Recommended Transmitter (DS90CF363) to AND10pSi104EAS-HB Interface Assignment: 6-bit Transmitter

| DS90CF363 | | | | ANDpSi10C313U | | |
|--------------------|-----------|---|---------------------------------|------------------------|-----------------|--------------------|
| Input Terminal No. | | Input Signal (Graphics controller output signal) | | Output Signal Symbol | Interface (CN1) | |
| Symbol | DS90CF363 | Symbol | Function | | Terminal | Symbol |
| TIN0 | 44 | R0 | Red Pixels Display Data (LSB) | TOUT0- TOUT0+ | No.5 No.6 | IN0- IN0+ |
| TIN1 | 45 | R1 | Red Pixels Display Data | | | |
| TIN2 | 47 | R2 | Red Pixels Display Data | | | |
| TIN3 | 48 | R3 | Red Pixels Display Data | | | |
| TIN4 | 1 | R4 | Red Pixels Display Data | | | |
| TIN5 | 3 | R5 | Red Pixels Display Data (MSB) | | | |
| TIN6 | 4 | G0 | Green Pixels Display Data (LSB) | TOUT1- TOUT1+ | No.7 No.8 | IN1- IN1+ |
| TIN7 | 6 | G1 | Green Pixels Display Data | | | |
| TIN8 | 7 | G2 | Green Pixels Display Data | | | |
| TIN9 | 9 | G3 | Green Pixels Display Data | | | |
| TIN10 | 10 | G4 | Green Pixels Display Data | | | |
| TIN11 | 12 | G5 | Green Pixels Display Data (MSB) | | | |
| TIN12 | 13 | B0 | Blue Pixels Display Data (LSB) | TOUT2- TOUT2+ | No.9 No.10 | IN2- IN2+ |
| TIN13 | 15 | B1 | Blue Pixels Display Data | | | |
| TIN14 | 16 | B2 | Blue Pixels Display Data | | | |
| TIN15 | 18 | B3 | Blue Pixels Display Data | | | |
| TIN16 | 19 | B4 | Blue Pixels Display Data | | | |
| TIN17 | 20 | B5 | Blue Pixels Display Data (MSB) | | | |
| TIN18 | 22 | NC | Non Connection (open) | TCLK OUT- TCLK OUT+ | No.11 No.12 | CLK IN- CLK IN+ |
| TIN19 | 23 | NC | Non Connection (open) | | | |
| TIN20 | 25 | ENAB | Compound Synchronization Signal | | | |
| CLK IN | 26 | NCLK | Data Sampling Clock | | | |

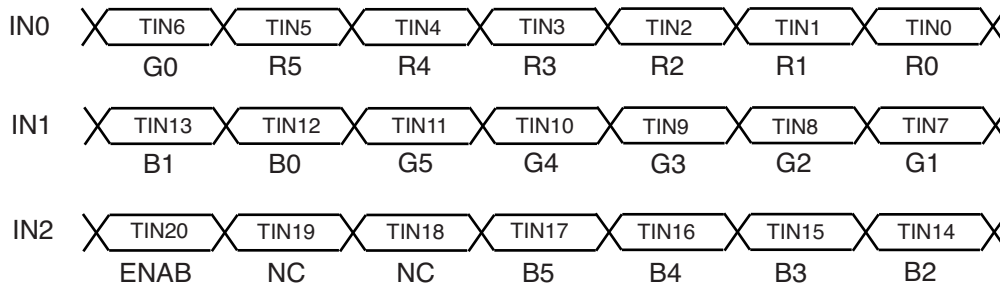

Recommended Transmitter (DS90CF383) to AND10pSi104EAS-HB Interface Assignment: 8-bit Transmitter

| DS90CF383 | | | | ANDpSi10C313U | | |
|--------------------|-----------|---|---------------------------------|----------------------------|-----------------|--------------------|
| Input Terminal No. | | Input Signal (Graphics controller output signal) | | Output Signal Symbol | Interface (CN1) | |
| Symbol | DS90CF383 | Symbol | Function | | Terminal | Symbol |
| TIN0 | 51 | R0 | Red Pixels Display Data (LSB) | TOUT0- TOUT0+ | No.12 No.11 | IN0- IN0+ |
| TIN1 | 52 | R1 | Red Pixels Display Data | | | |
| TIN2 | 54 | R2 | Red Pixels Display Data | | | |
| TIN3 | 55 | R3 | Red Pixels Display Data | | | |
| TIN4 | 56 | R4 | Red Pixels Display Data | | | |
| TIN6 | 3 | R5 | Red Pixels Display Data (MSB) | TOUT1- TOUT1+ | No.10 No.9 | IN1- IN1+ |
| TIN7 | 4 | G0 | Green Pixels Display Data (LSB) | | | |
| TIN8 | 6 | G1 | Green Pixels Display Data | | | |
| TIN9 | 7 | G2 | Green Pixels Display Data | | | |
| TIN12 | 11 | G3 | Green Pixels Display Data | | | |
| TIN13 | 12 | G4 | Green Pixels Display Data | TOUT2- TOUT2+ | No.8 No.7 | IN2- IN2+ |
| TIN14 | 14 | G5 | Green Pixels Display Data (MSB) | | | |
| TIN15 | 15 | B0 | Blue Pixels Display Data (LSB) | | | |
| TIN18 | 19 | B1 | Blue Pixels Display Data | | | |
| TIN19 | 20 | B2 | Blue Pixels Display Data | | | |
| TIN20 | 22 | B3 | Blue Pixels Display Data | TOUT3- TOUT3+ | - | - |
| TIN21 | 23 | B4 | Blue Pixels Display Data | | | |
| TIN22 | 24 | B5 | Blue Pixels Display Data (MSB) | | | |
| TIN24 | 27 | NC | Non Connection (open) | | | |
| TIN25 | 28 | NC | Non Connection (open) | | | |
| TIN26 | 30 | ENAB | Compound Synchronization Signal | TCLK OUT- TCLK OUT+ | No.6 No.5 | CLK IN- CLK IN+ |
| TIN27 | 50 | NC | Non Connection (open) | | | |
| TIN5 | 2 | NC | Non Connection (open) | | | |
| TIN10 | 8 | NC | Non Connection (open) | | | |
| TIN11 | 10 | NC | Non Connection (open) | | | |
| TIN16 | 16 | NC | Non Connection (open) | | | |
| TIN17 | 18 | NC | Non Connection (open) | | | |
| TIN23 | 25 | NC | Non Connection (open) | | | |
| CLK IN | 31 | NCLK | Data Sampling Clock | | | |

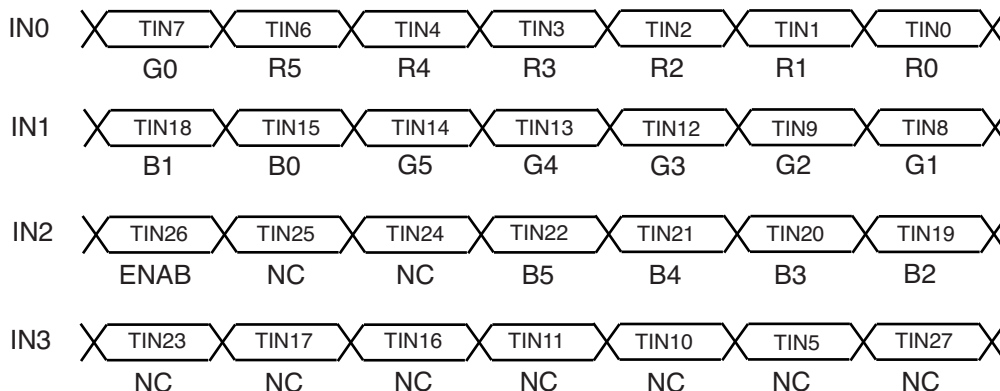

Note (2): 256K colors are displayed by the combinations of 18 data bits.

| | Display | R5 | R4 | R3 | R2 | R1 | R0 | G5 | G4 | G3 | G2 | G1 | G0 | B5 | B4 | B3 | B2 | B1 | B0 | Gray Scale Level | |
|-----------------------------|----------------|------|----|----|----|----|----|----|----|----|----|----|----|----|----|----|----|----|----|------------------|--------|
| Basic Color | Black | L | L | L | L | L | L | L | L | L | L | L | L | L | L | L | L | L | L | - | |
| | Blue | L | L | L | L | L | L | L | L | L | L | L | L | H | H | H | H | H | H | - | |
| | Green | L | L | L | L | L | L | H | H | H | H | H | H | L | L | L | L | L | L | - | |
| | Lt. Blue | L | L | L | L | L | L | H | H | H | H | H | H | H | H | H | H | H | H | - | |
| | Red | H | H | H | H | H | H | L | L | L | L | L | L | L | L | L | L | L | L | - | |
| | Purple | H | H | H | H | H | H | L | L | L | L | L | L | H | H | H | H | H | H | - | |
| | Yellow | H | H | H | H | H | H | H | H | H | H | H | H | L | L | L | L | L | L | - | |
| | White | H | H | H | H | H | H | H | H | H | H | H | H | H | H | H | H | H | H | - | |
| Gray Scale of Red | Black | L | L | L | L | L | L | L | L | L | L | L | L | L | L | L | L | L | L | L0 | |
| | Dark ↑ ↓ | Dark | L | L | L | L | L | H | L | L | L | L | L | L | L | L | L | L | L | L | L1 |
| | | | L | L | L | L | H | L | L | L | L | L | L | L | L | L | L | L | L | L | L2 |
| | | | : | : | : | : | : | : | : | : | : | : | : | : | : | : | : | : | : | : | L3~L60 |
| | | | : | : | : | : | : | : | : | : | : | : | : | : | : | : | : | : | : | : | |
| | | H | H | H | H | L | H | L | L | L | L | L | L | L | L | L | L | L | L | L61 | |
| | Light | H | H | H | H | H | L | L | L | L | L | L | L | L | L | L | L | L | L | L62 | |
| | Red | H | H | H | H | H | H | L | L | L | L | L | L | L | L | L | L | L | L | Red L63 | |
| Gray Scale of Green | Black | L | L | L | L | L | L | L | L | L | L | L | L | L | L | L | L | L | L | L0 | |
| | Dark ↑ ↓ | Dark | L | L | L | L | L | L | L | L | L | L | L | H | L | L | L | L | L | L | L1 |
| | | | L | L | L | L | L | L | L | L | L | L | H | L | L | L | L | L | L | L | L2 |
| | | | : | : | : | : | : | : | : | : | : | : | : | : | : | : | : | : | : | : | L3~L60 |
| | | | : | : | : | : | : | : | : | : | : | : | : | : | : | : | : | : | : | : | |
| | | L | L | L | L | L | L | H | H | H | H | L | H | L | L | L | L | L | L | L61 | |
| | Light | L | L | L | L | L | L | H | H | H | H | H | L | L | L | L | L | L | L | L62 | |
| | Green | L | L | L | L | L | L | H | H | H | H | H | H | L | L | L | L | L | L | Green L63 | |
| Gray Scale of Blue | Black | L | L | L | L | L | L | L | L | L | L | L | L | L | L | L | L | L | L | L0 | |
| | Dark ↑ ↓ | Dark | L | L | L | L | L | L | L | L | L | L | L | L | L | L | L | L | L | H | L1 |
| | | | L | L | L | L | L | L | L | L | L | L | L | L | L | L | L | L | H | L | L2 |
| | | | : | : | : | : | : | : | : | : | : | : | : | : | : | : | : | : | : | : | L3~L60 |
| | | | : | : | : | : | : | : | : | : | : | : | : | : | : | : | : | : | : | : | |
| | | L | L | L | L | L | L | L | L | L | L | L | L | H | H | H | H | L | H | L61 | |
| | Light | L | L | L | L | L | L | L | L | L | L | L | L | H | H | H | H | H | L | L62 | |
| | Blue | L | L | L | L | L | L | L | L | L | L | L | L | H | H | H | H | H | H | Blue L63 | |
| Gray Scale of White & Black | Black | L | L | L | L | L | L | L | L | L | L | L | L | L | L | L | L | L | L | L0 | |
| | Dark ↑ ↓ | Dark | L | L | L | L | L | H | L | L | L | L | L | H | L | L | L | L | L | H | L1 |
| | | | L | L | L | L | H | L | L | L | L | L | H | L | L | L | L | L | H | L | L2 |
| | | | : | : | : | : | : | : | : | : | : | : | : | : | : | : | : | : | : | : | L3~L60 |
| | | | : | : | : | : | : | : | : | : | : | : | : | : | : | : | : | : | : | : | |
| | | H | H | H | H | L | H | H | H | H | H | L | H | H | H | H | H | L | H | L61 | |
| | Light | H | H | H | H | H | L | H | H | H | H | H | L | H | H | H | H | H | L | L62 | |
| | White | H | H | H | H | H | H | H | H | H | H | H | H | H | H | H | H | H | H | White L63 | |