

G Series

FEATURES

- Compact design, substantial space saving
- Simple assembly
- CE approved types

The essential features of the thumb-wheel switch are its high reliability, precision and contact endurance.

InterSwitch thumbwheel switches are used in machine tool control systems, measurement and test units, control and regulation systems, computer systems, sound and vision control systems, telecommunications, medical measurement systems, etc.



SPECIFICATIONS

Rates current (resistive load)	1-100 mA AC/DC		
Max. current carrying capacity	1 A AC/DC		
Max. working voltage	max. 42 V AC/DC		
Test voltage	500 V DC		
Insulation resistance (+20°C)	10 ⁵ MOhm		
Contact resistance (ind. PCB)	100 MOhm		
Servicelife (switch operations)	min. 10 ⁵		
Permissible ambient temp.	-25° ... +70°C		
10 positions	Yes	Direct solder connections	Yes
16 positions	Yes	Edge connections	Yes
Decimal	Yes	Solder pins	Yes
Binary	Yes	Wire wrap pins	Yes
Binary + Complement	Yes	Front mounting	Yes
PCB for diode mounting	Yes	Ganged switches	Yes



Interswitch Thumbwheel Switches – G Series

Dimensions	
Width in mm	12.5
Height in mm	58
Mounting depth in mm	min. 57.1
Character height in mm	4

Top View

n= Number of modules without end brackets
(1 pair of division plates 1 element)

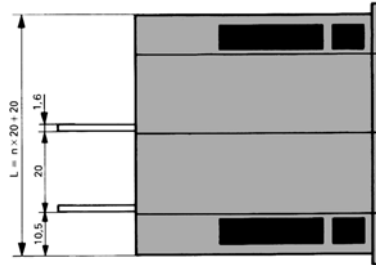

Front View

Panel Cut-Out

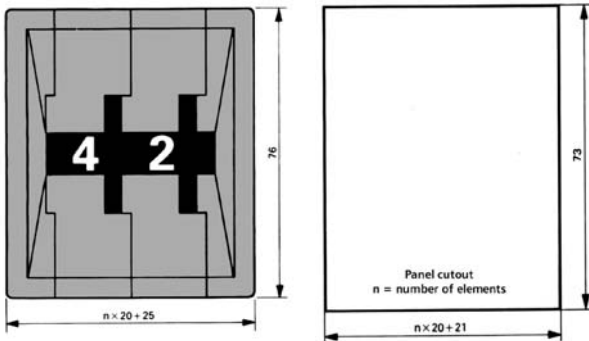

Side View

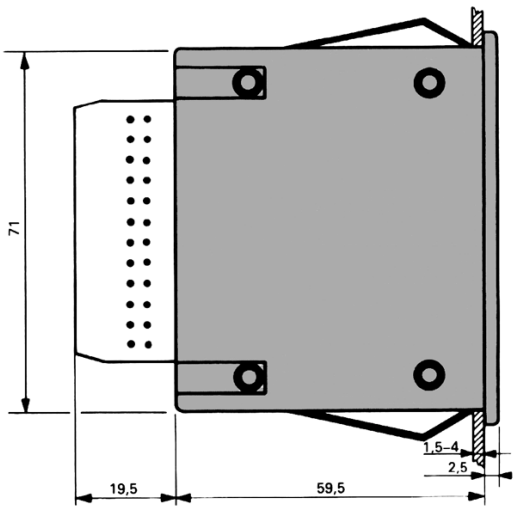

PCB Design

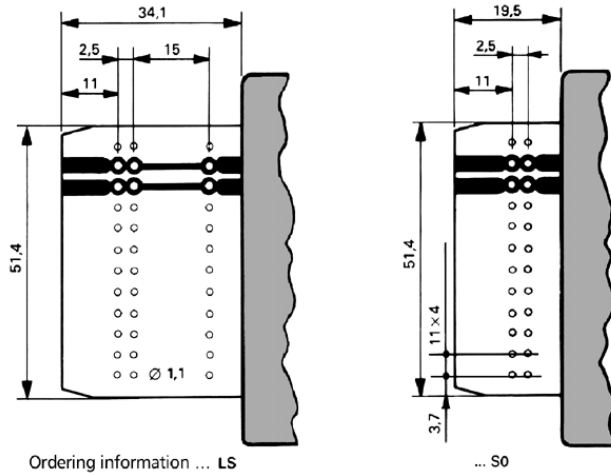

Division Plates and End Brackets

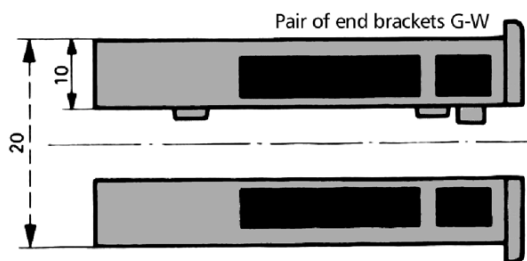
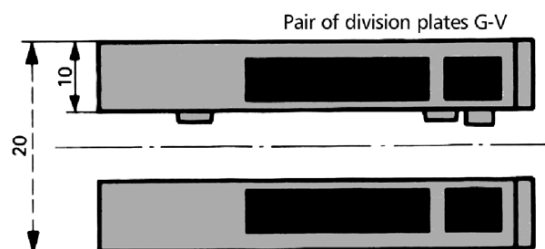

Code 001

Three-pole change-over switch

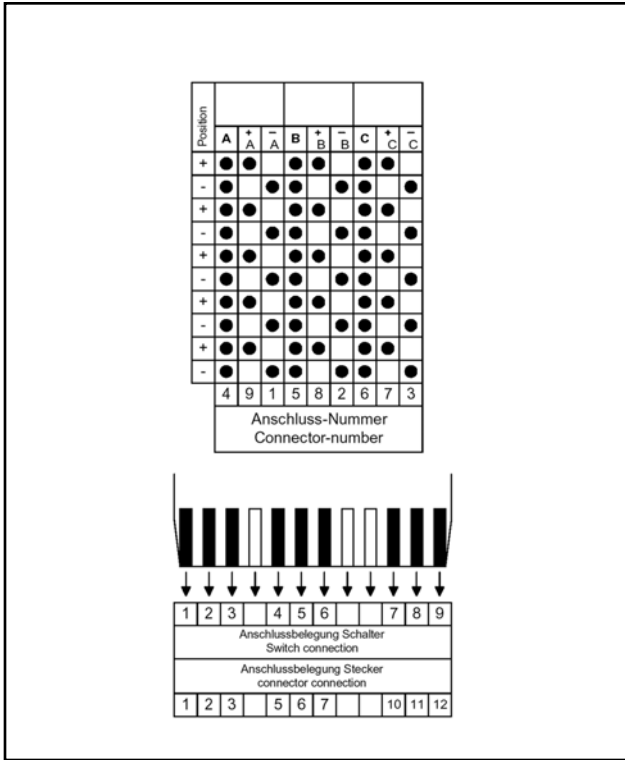

Code 010

Decimal 0-9

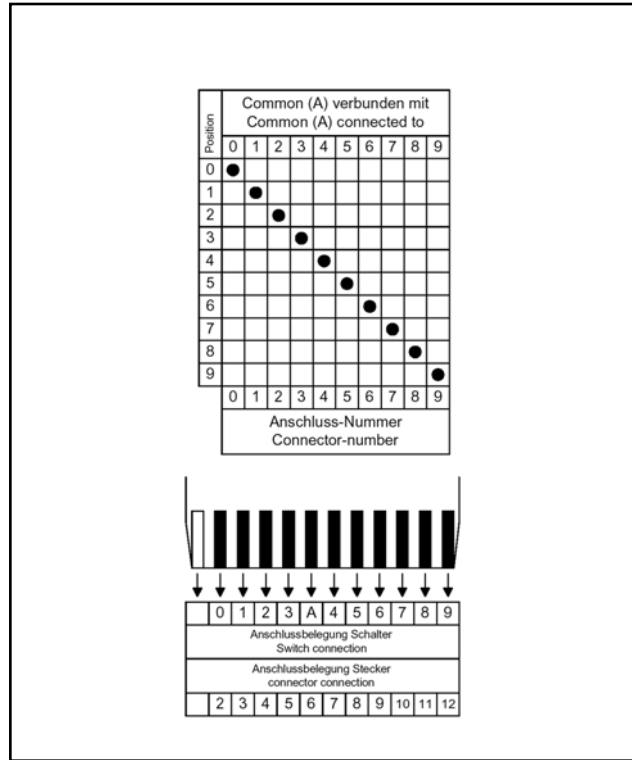

Code 031

BCD Positive + Complement

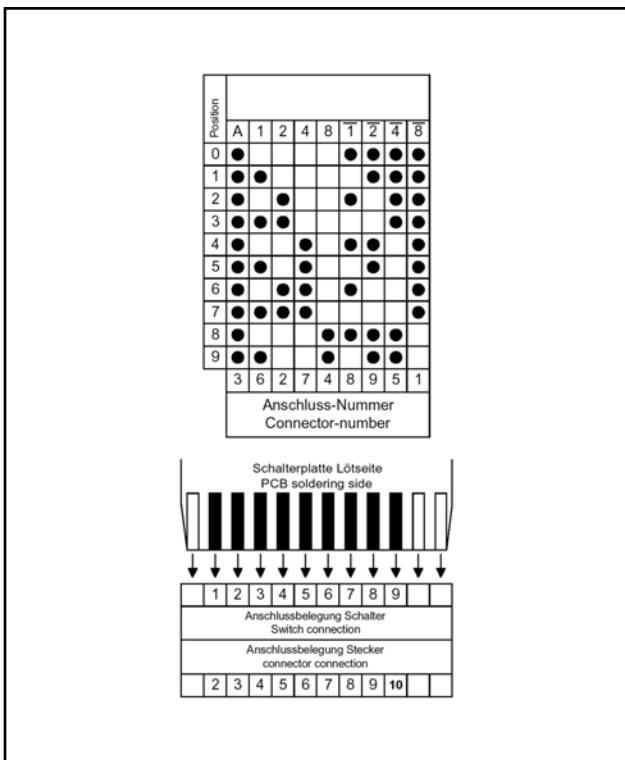

Code 032

1 – 2 – 2' – 4 Code

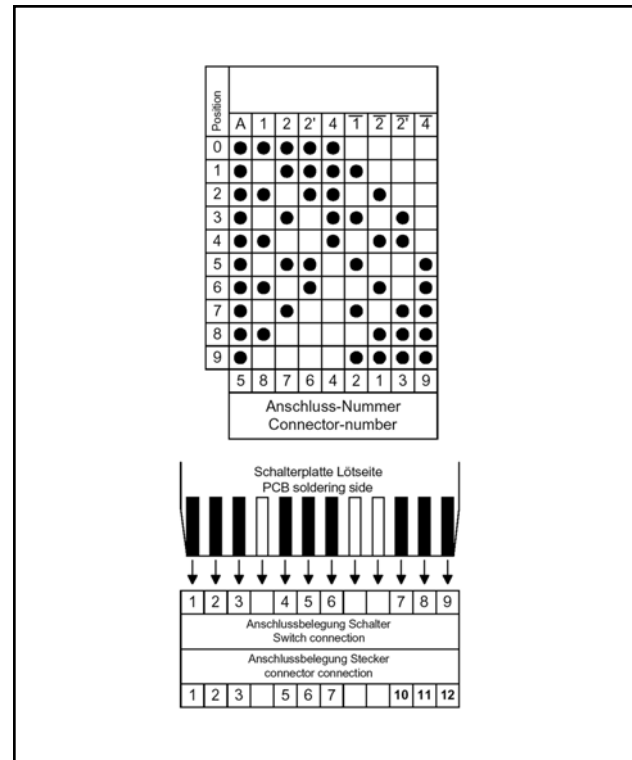



InterSwitch Thumbwheel Switches – G Series

Code 044

BCD Positive + Comp. - make before break contacts

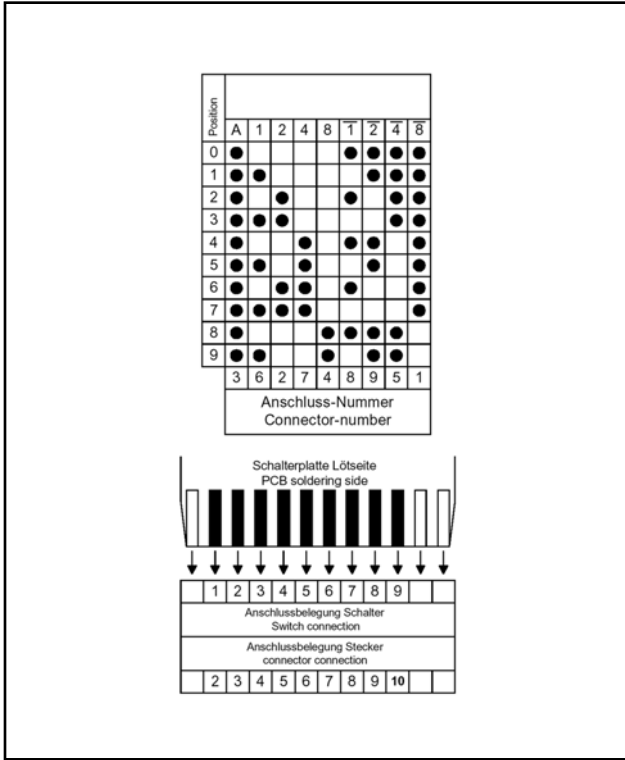

Code 138

Balance Code

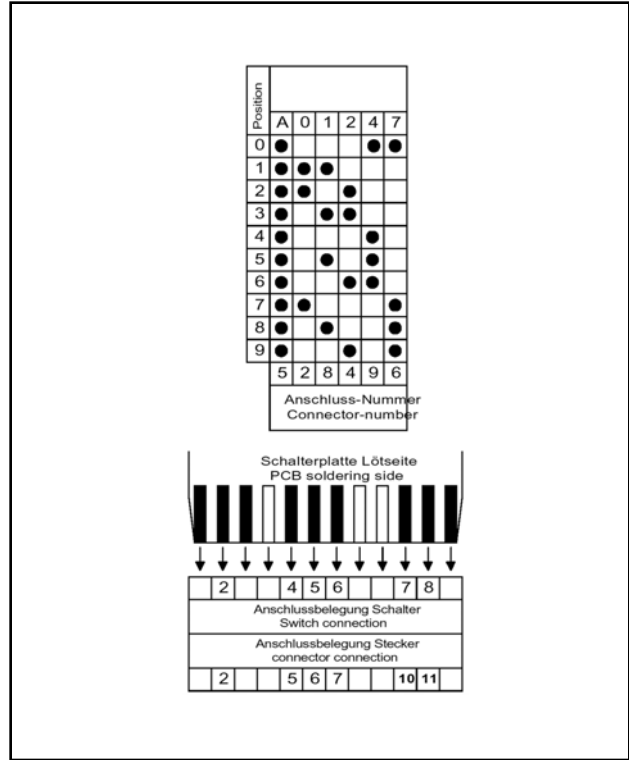

Code 140

BCD + 2 Inputs

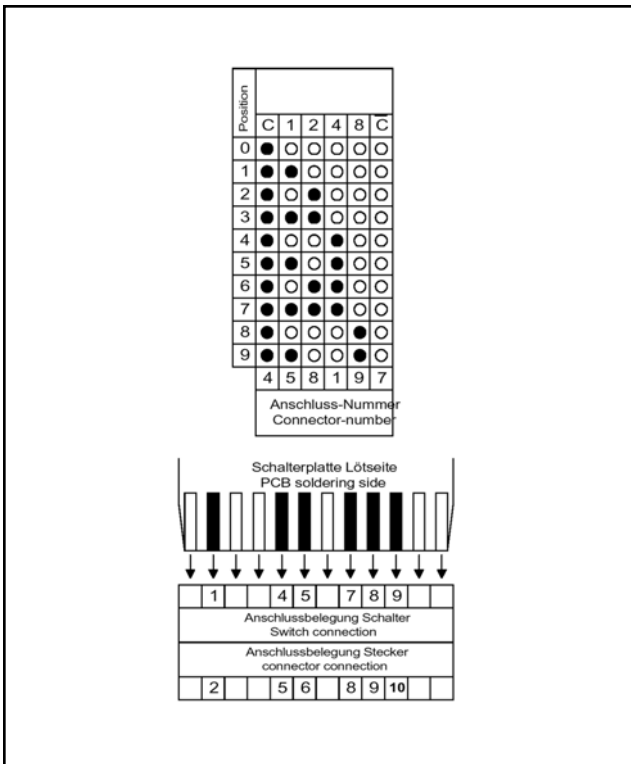

Product specifications contained herein may be changed without prior notice. It is therefore advisable to contact Purdy Electronics before proceeding with the design of equipment incorporating this product.